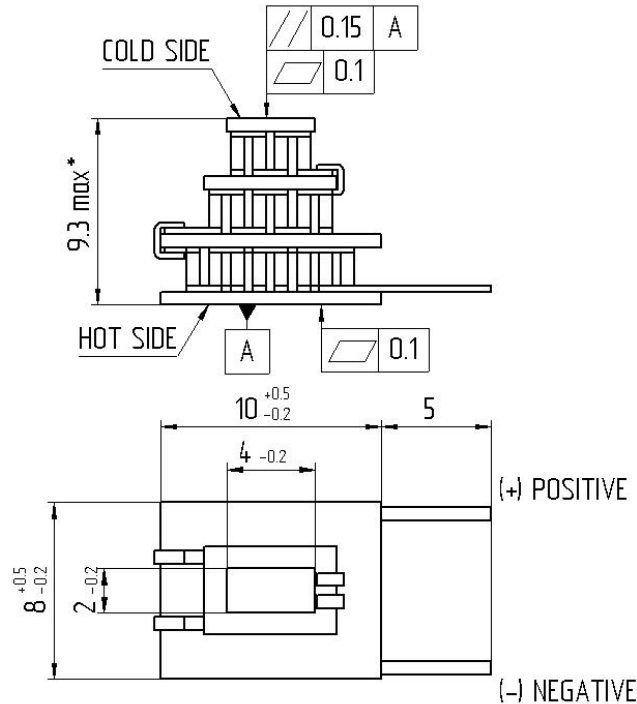
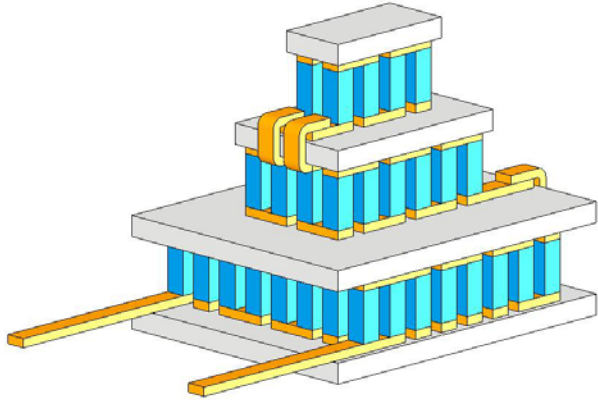

SPECIFICATION OF THERMOELECTRIC MODULE TB-3-(31-11-4)-1.5

*Tolerance of the TEC's height for a lot is ± 0.35 mm

Thermoelectric parameters	Unit	Value
I_{max}	Amps	0.9
U_{max}	Volts	3.5
ΔT_{max}	K	109
Q_{max}	Watts	0.4
Tolerance	%	±10

All parameters except R_{ac} are given at Th=300 K

Assembly parameters	Unit	Value
Wires	-	-
Cross section	mm²	-
Metallization	-	Not
Sealing	-	Not
Internal solder	°C	139
Brazing solder	°C	not

Operation parameters	Unit	Value
Working temperature range	°C	-50 ÷ +80
Max. processing temperature	°C	120
ROHS compliance	-	YES

